

JVC



MICRO COMPONENT SYSTEM

小型組合音響設備

نظام مكونات فائق الصغر

UX-V50V UX-V50GN

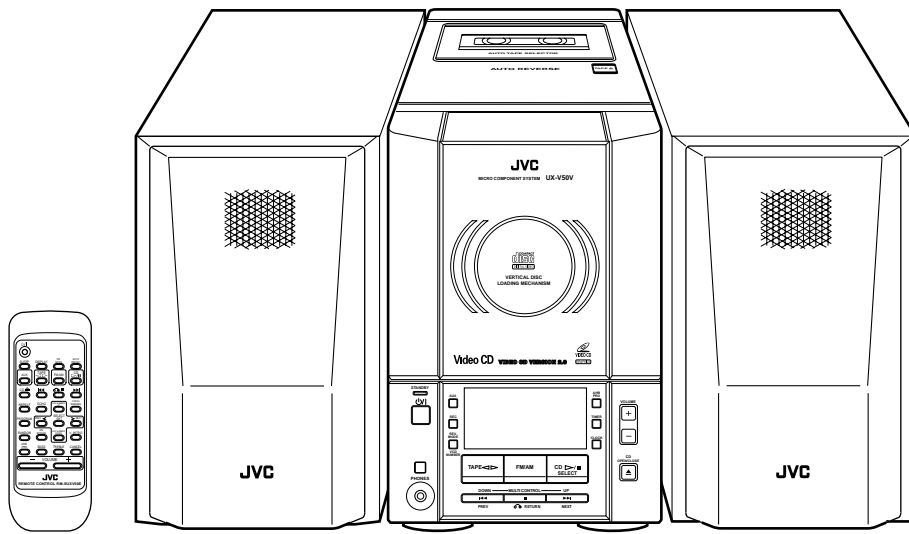

PlayBack
Control



INSTRUCTIONS

使用説明書

كتيب تعليمات التشغيل

For Customer Use:

Enter below the Model No. and Serial No. which are located either on the rear, bottom or side of the cabinet. Retain this information for future reference.

Model No. _____

Serial No. _____

GVT0034-003A
[U/UB/US/UX/UT]

Warnings, Cautions and Others

警告，注意及其他須知事項

تحذيرات، تنبيهات وأشياء أخرى

Caution — ⏻ switch!

Disconnect the mains plug to shut the power off completely. The ⏻ switch in any position does not disconnect the mains line. The power can be remote controlled.

注意— ⏻ 開關！

無論⏻開關在任何位置，電源線的電源還是沒有被切斷，若要將電源完全關閉，應把電源插頭拔離插座。電源開關可用遙控器控制。

تحذير - ⏻ الطاقة

انزع قابس الطاقة الكهربائية من أجل فصل الطاقة الكهربائية عن الجهاز كلياً. لا يفصل مفتاح الطاقة الكهربائية عندما يكون باي وضع ⏻ الطاقة الكهربائية عن الجهاز. يمكن التحكم عن بعد بالطاقة الكهربائية.

CAUTION

To reduce the risk of electrical shocks, fire, etc.:

1. Do not remove screws, covers or cabinet.
2. Do not expose this appliance to rain or moisture.

警告

為了減低觸電，火災等危險：

1. 請勿擅自卸下螺絲釘，蓋子或機殼。
2. 切勿讓本機受雨淋或置潮濕環境中。

تحذير

لتجنب خطر الحريق، الصدمات الكهربائية، الخ.:

١. لا تقم بفك البراغي، الاغطية أو الخزانات.
٢. لا تقم بتعريض هذا الجهاز للمطر أو للرطوبة.

Caution: Proper Ventilation

To avoid risk of electric shock and fire, and to prevent damage, locate the apparatus as follows:

1 Front:

No obstructions and open spacing.

2 Sides/ Top/ Back:

No obstructions should be placed in the areas shown by the dimensions below.

3 Bottom:

Place on the level surface. Maintain an adequate air path for ventilation by placing on a stand with a height of 10 cm or more.

告誡：正確通風

為免發生觸電和火警的危險，及防止本機受損，請將本機如下放置：

1 前面： 沒有障碍物及地方開闊。

2 側面／頂面／背面： 在圖中所示範圍中，不應放置任何障礙物。

3 底部： 放置在水平面上。放置在一個高 10 厘米或以上的臺上，以保持足夠的通風道。

تحذير: التهوية الصحيحة

لتجنب حصول صدمات كهربائية واطار الحريق ومنع حصول تلف وضرر للجهاز، ركّب الجهاز كما يلي:
١ الجهة الامامية: يجب ان لا يكون هنالك عوائق ويجب ان تكون المنطقة مفتوحة امام الجهاز.
٢ الجهات الجانبية / العلوية / الخلفية: يجب عدم وضع عوائق في المناطق المبينة بالابعاد في الاسفل.
٣ القاعدة: يجب وضع الجهاز على سطح منبسط. اترك مسافة كافية من اجل التهوية بواسطة وضع الجهاز على حامل بارتفاع ١٠ سم او اكثر.

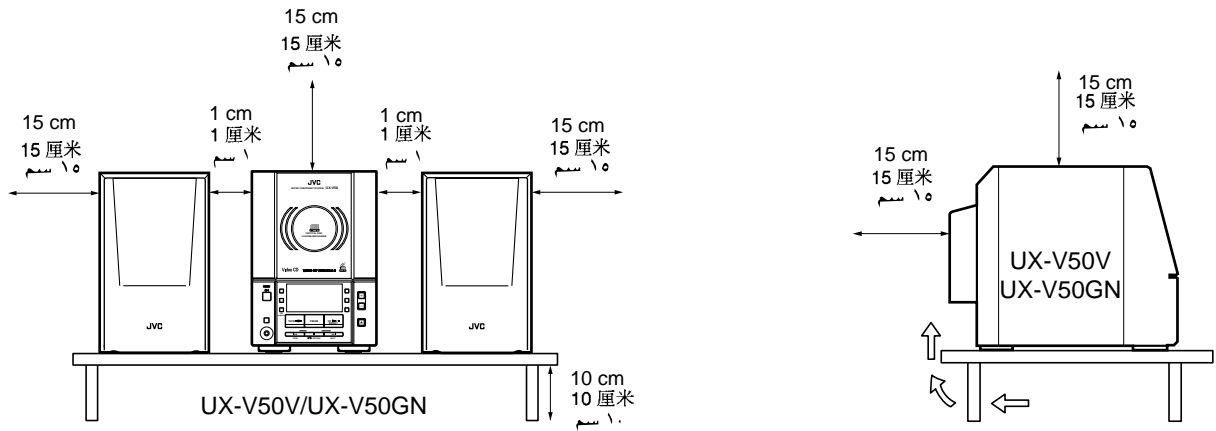

IMPORTANT FOR LASER PRODUCTS

/ 雷射產品的重要說明 / مهم للمنتجات الليزرية

REPRODUCTION OF LABELS / 標籤內容說明 / إنتاج اللاصقات

① CLASSIFICATION LABEL, PLACED ON REAR ENCLOSURE

① 分類標籤，貼在機殼背後。

① لاصق التصنيف، موضوعة على المرفق الخلفي

② WARNING LABEL, PLACED INSIDE THE UNIT

② 警告標籤，貼於機內。

② لاصقة التحذير، موضوعة بداخل الجهاز

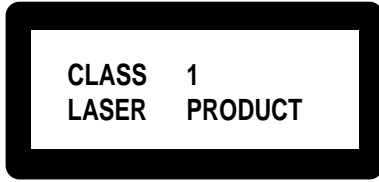

DANGER: Invisible laser radiation when open and interlock failed or defeated. AVOID DIRECT EXPOSURE TO BEAM. (e)

VARNING: Osynlig laserstrålning när denna del är öppnad och spärren är urkopplad. Betrakta ej strålen. (s)

ADVARSEL: Usynlig laserstrålning ved åbning, når sikkerhedsafbrydere er ude af funktion. Undgå udsættelse for stråling (d)

VARO: Avattaessa ja suojalukitus ohitettaessa olet alltiina näkymättömälle lasersäteilylle. Älä katso säteeseen. (f)

1. CLASS 1 LASER PRODUCT
2. **DANGER:** Invisible laser radiation when open and interlock failed or defeated. Avoid direct exposure to beam.
3. **CAUTION:** Do not open the top cover. There are no user serviceable parts inside the Unit; leave all servicing to qualified service personnel.

1. 一級雷射產品
2. **危險：**當內部鎖定裝置失效或者損壞後，打開蓋板可能會產生不可見的雷射輻射。應避免受到光束直接照射。
3. **注意：**請勿打開頂蓋板。本機內部沒有用戶可自行維修的部件；所有維修工作應由有資格的人員完成。

1. صنف ١ منتج ليزري
2. **خطر:** هنالك أشعة ليزرية غير مرئية عند الفتح والإغلاق غير الضروري أو غير الصحيح. تجنب التعرض المباشر للأشعة.
3. **تحذير:** ات تفتح الغطاء العلوي. لا يوجد اجزاء داخل الجهاز يستطيع المستخدم صيانتها. في حالة الحاجة للصيانة، اترك جميع اعمال الصيانة للأشخاص المختصين فقط.

Thank you for purchasing the JVC Micro Component System.

We hope it will be a valued addition to your home, giving you years of enjoyment.

Be sure to read this instruction manual carefully before operating your new stereo system.

In it you will find all the information you need to set up and use the system.

If you have any query that is not answered by the manual, please contact your dealer.

Features

Here are some of the things that make your System both powerful and simple to use.

- The controls and operations have been designed to make them very easy to use, freeing you to just enjoy the music and movies.
 - With JVC's **COMPU PLAY** you can turn on the System and automatically start the Radio, Cassette deck or CD Player with a single touch.
- The System incorporates Active Hyper Bass PRO circuitry to faithfully reproduce low frequency sounds.
- Forty-five-station preset capability (30 FM and 15 AM) in addition to auto-seek and manual tuning.
- Versatile CD play mode options include repeat, random and program play.
- Timer functions; Daily Timer, Recording Timer and Sleep Timer.
- Auto-reverse tape function.
- You can connect various external equipment.
 - For Hong Kong, external equipment may be used for playback and recording.
 - For other areas, it may only be used for playback.



How This Manual Is Organized

- Basic information that is the same for many different functions – e.g. setting the volume – is given in the section “Common Operations,” and not repeated under each function.
- The names of buttons/controls and display messages are written in all capital letters: e.g. TAPE, “NO DISC.”

IMPORTANT PRECAUTIONS

1 Installation of the System

- Select a place which is level, dry and neither too hot nor too cold. (Between 5°C and 35°C.)
- Leave sufficient distance between the System and a TV.
- Do not use the System in a place subject to vibrations.

2 Power cord

- Do not handle the power cord with wet hands!
- Some power is always consumed as long as the power cord is connected to the wall outlet.
- When unplugging the System from the wall outlet, always pull the plug, not the power cord.

3 Malfunctions, etc.

- There are no user serviceable parts inside. In case of a system failure, unplug the power cord and consult your dealer.
- Do not insert any metallic object into the System.

Table of Contents

Features	1	Using the Cassette Deck (Recording)	18
How This Manual Is Organized	1	Using External Equipment	20
IMPORTANT PRECAUTIONS	1	Using the Timers	21
Getting Started	2	Using the Microphone	24
Common Operations	6	Care and Maintenance	26
Using the Tuner	8	Troubleshooting	27
Using the CD Player (Audio CDs)	10	Specifications	28
Using the Video CD Player (VCDs and CD-Gs)	13		
Using the Cassette Deck (Listening to a Tape)	17		

Getting Started

Accessories

Make sure that you have all of the following items, which are supplied with the System.

- AC Power Cord (1)
- AM Loop Antenna (1)
- Remote Control (1)
- Batteries (2)
- FM Wire Antenna (1)
- AC Plug Adaptor (except for Hong Kong and Argentina) (1)
- Video Cord (1)

If any of these items are missing, contact your dealer immediately.

Setting the VOLTAGE SELECTOR Switch

To avoid damaging the System, set the voltage before plugging in the system.

Set the correct voltage for your area with the VOLTAGE SELECTOR switch on the back of the Unit. Use a screwdriver to rotate the selector so that the voltage number the arrow is pointed at is the same as the voltage in your area.

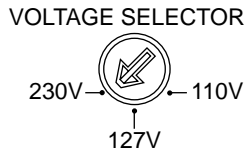

How to Put Batteries in the Remote Control

Match the polarity (+ and -) on the batteries with the + and - markings in the battery compartment.

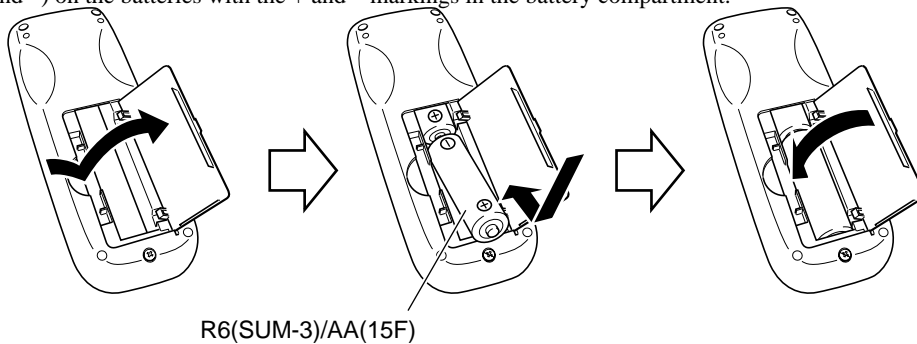

CAUTION: Handle batteries properly.

To avoid battery leakage or explosion:

- Remove batteries when the Remote Control will not be used for a long time.
- When you need to replace the batteries, replace both batteries at the same time with new ones.
- Do not use an old battery with a new one.
- Do not use different types of batteries together.

Using the Remote Control

The Remote Control makes it easy to use many of the functions of the System from a distance of up to 7 m away. You need to point the Remote Control at the remote sensor on the System's front panel.

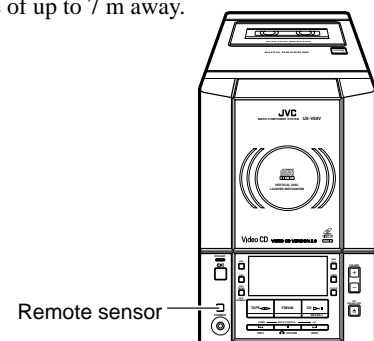

CAUTION: Make all connections before plugging the System into an AC power outlet.

Connecting the FM Antenna

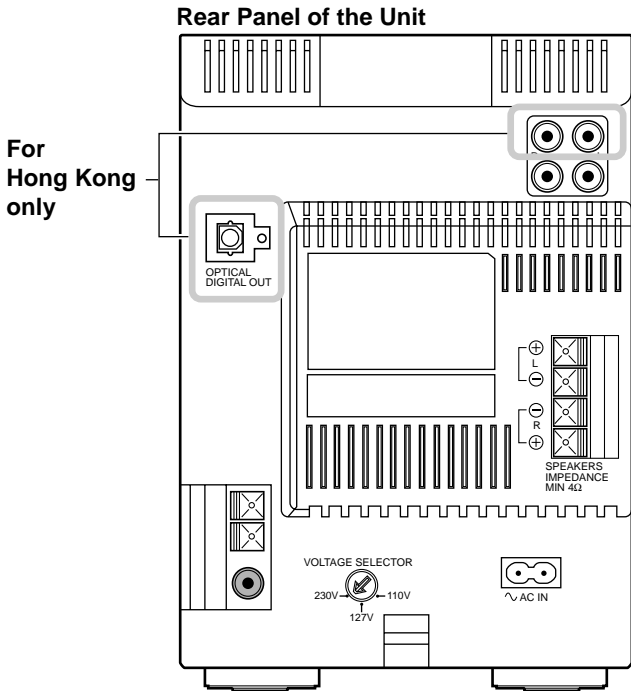

Using the supplied Wire Antenna

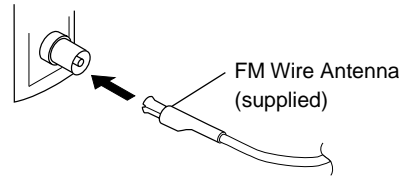

Using the coaxial type connector (not supplied)

A 75 Ω antenna with coaxial type connector (IEC or DIN 45325) should be connected to the FM (75 Ω) COAXIAL terminal.

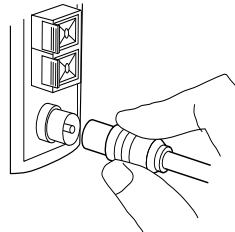

If reception is poor, connect the outdoor antenna.

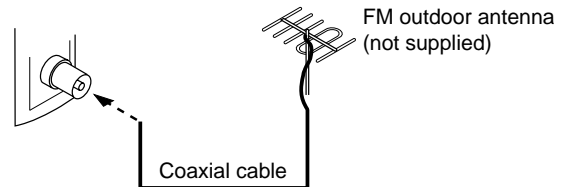

Note: Before attaching a 75 Ω coaxial lead (the kind with a round wire going to an outdoor antenna), disconnect the supplied FM Wire Antenna.

Connecting the AM Antenna

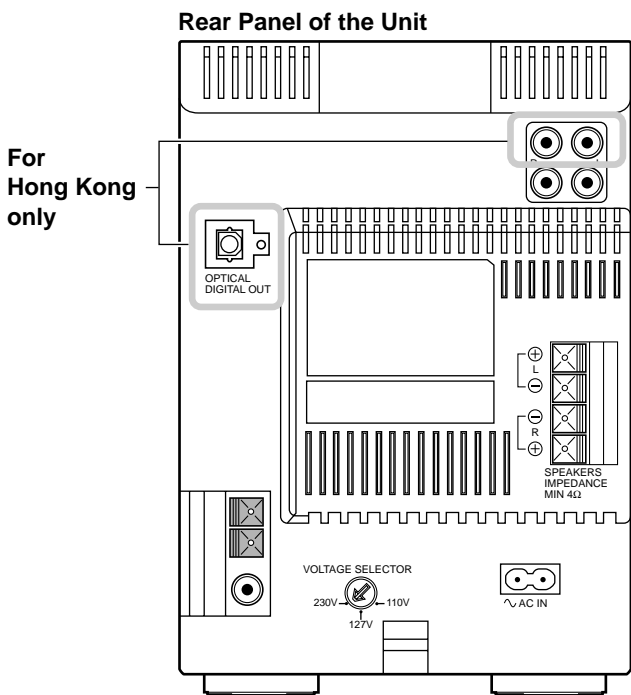

AM Loop Antenna (supplied)

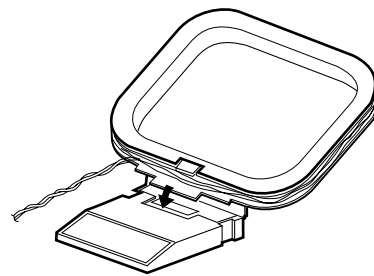

Attach the AM loop to its base by snapping the tabs on the loop into the slot in the base.

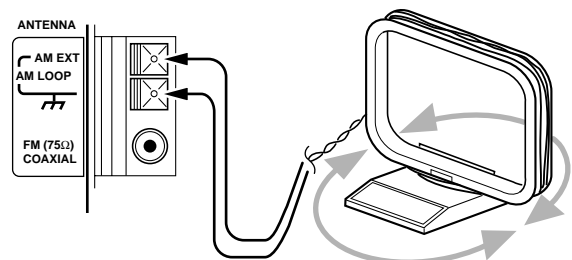

Turn the loop until you have the best reception.

CAUTION: To avoid noise, keep antennas away from the System, the connecting cord and the AC power cord.

CAUTION: Make all connections before plugging the System into an AC power outlet.

Connecting the Speakers

For each speaker, connect one end of the speaker wire to the speaker terminal on the back of the System.

1. Open the terminals and insert the speaker wires firmly, then close the terminals.
2. Connect the red (+) and black (-) wires of the right side speaker to the red (+) and black (-) terminals marked R on the System.
Connect the red (+) and black (-) wires of the left side speaker to the red (+) and black (-) terminals marked L on the System.

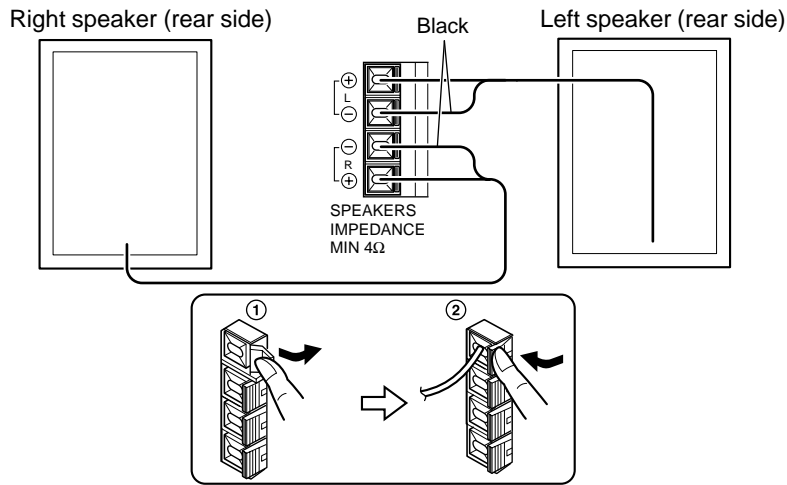

CAUTION:

If a TV is installed near the speakers, the picture on the TV may be distorted. If this happens, set the speakers away from the TV.

Connecting External Equipment

For Hong Kong:

Connect signal cords (not supplied) between the System's LINE IN (AUX)/LINE OUT terminals and the output/input terminals of an external MD recorder, cassette deck, etc.

You can then listen to the external source through the System, or record the System's CD player, cassette tape, or tuner to the external unit.

For other areas:

You can connect audio equipment — used only as a playback device.

Connect the audio output terminals on the other equipment and the LINE IN (AUX) terminals on the rear, using a signal cord (not supplied).

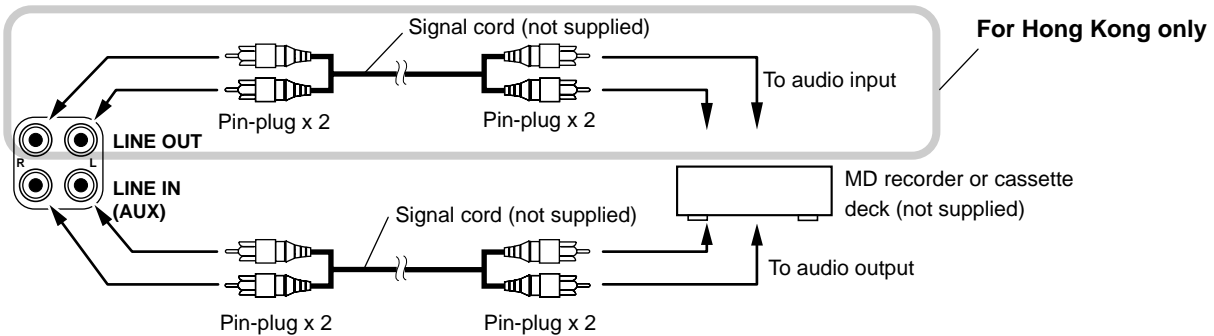

Connecting a TV

Connect the video cord (supplied) between the System's VIDEO OUT terminal and the video input jack of your TV. When you want to listen to the music on your TV, connect the signal cord (not supplied) between the System's LINE OUT terminals and the audio input jacks of your TV.

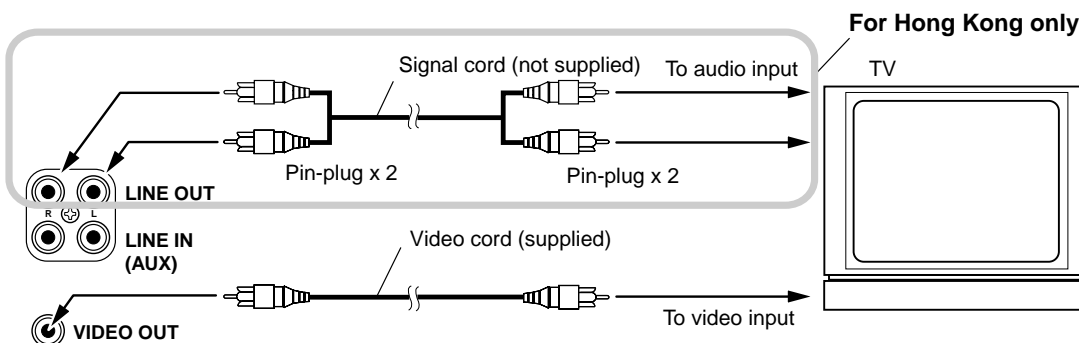

Connecting an MD Recorder, etc. (Digital Output) (For Hong Kong only)

Unplug the cap and connect an optical digital cord (not supplied) between the System's OPTICAL DIGITAL OUT terminal and the input terminal of an MD recorder, etc.

You can record the digital output signal from the System's CD Player to the MD recorder, etc.

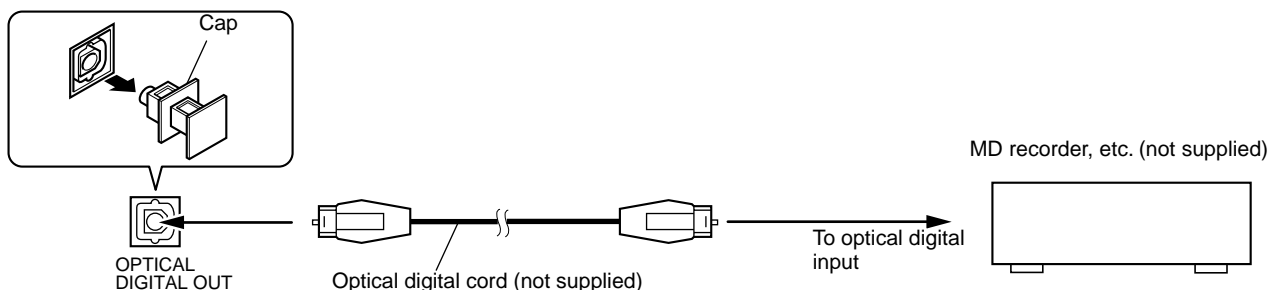

Connecting the AC Power Cord

Firmly insert the supplied AC power cord into the AC inlet on the back of the Unit.

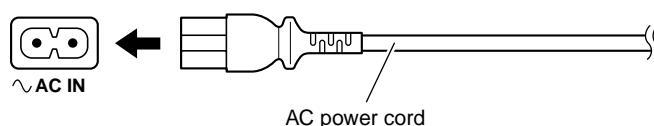

CAUTIONS:

- ONLY USE JVC POWER CORD PROVIDED WITH THIS SYSTEM TO AVOID MALFUNCTION OR DAMAGE TO THE SYSTEM.
- BE SURE TO UNPLUG THE POWER CORD FROM THE OUTLET WHEN YOU ARE GOING OUT OR WHEN THE SYSTEM IS NOT IN USE FOR AN EXTENDED PERIOD OF TIME.

Now you can plug the AC power cord into the wall outlet, and your System is at your command!

- EXCEPT FOR HONG KONG: IF YOUR WALL OUTLET DOES NOT MATCH THE AC PLUG, USE THE AC PLUG ADAPTOR SUPPLIED WITH YOUR SET.

COMPU PLAY

The JVC's COMPU PLAY feature lets you control the most frequently used System functions with a single touch.

With One Touch Operation you can play a CD, a tape, turn on the radio, or listen to an external equipment at a single press of the play button for that function. One Touch Operation turns the power on for you, then starts the function you have specified.

How One Touch Operation works in each case is explained in the section dealing with that function.

The COMPU PLAY buttons are:

On the Unit

- CD ▷/|| button
- FM/AM button
- TAPE <▷ button
- AUX button

On the Remote Control

- CD ▷/|| button
- FM/AM button
- TAPE <▷ button
- AUX button

AUTOMATIC POWER ON

The System automatically turns on with the following operation.

- When you press the CD OPEN/CLOSE ▲ button on the Unit (or CD ▲ button on the Remote Control), the System automatically turns on and the CD cover opens to allow CD insertion. However, this operation does not change the source to CD.
When you press the ⏻/| button to turn on or off the System, the CD cover will automatically close if it is open.

Common Operations

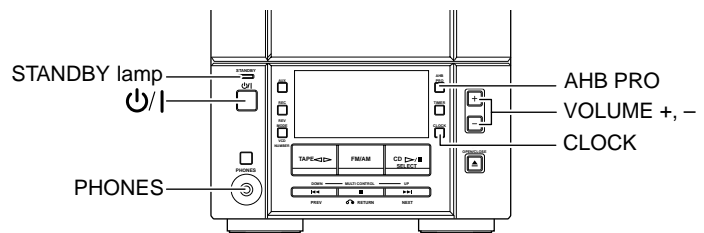
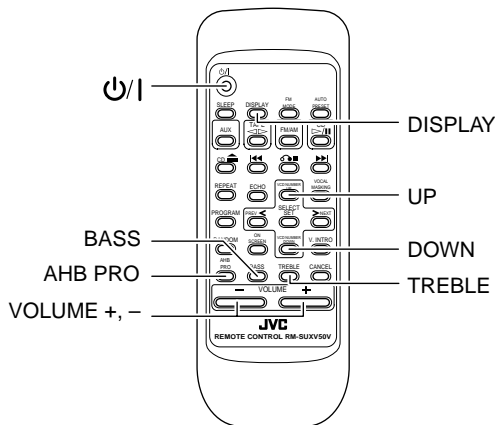

Turning the Power On and Off

Turning the System on -----

Press the P/I button.

The STANDBY lamp goes out.

The System comes on ready to play the source it was for when the power was last turned off.

- For example, if the last thing you were doing was listening to a CD, you are now ready to listen to a CD again. If you wish, you can change to another source.
- If you were listening to the Tuner last, the Tuner comes on playing the station it was last set to.

Turning the System off -----

Press the P/I button again.

The STANDBY lamp lights up.

- Some power is always consumed even though power is turned off (called Standby Mode).
- To switch off the System completely, unplug the AC power cord from the wall outlet. When you unplug the AC power cord, the clock will be reset to 0:00.

Adjusting the Volume

Press the VOLUME + button to increase the volume or press the VOLUME - button to decrease it.

VOLUME 15

You can adjust the volume level between 0 and 40.

CAUTION:

DO NOT turn off (on standby) the Unit with the volume set to an extremely high level; otherwise a sudden blast of sound could damage your hearing, speakers and/or headphones when you turn on the Unit or start playing any source next time.

REMEMBER you cannot adjust the volume level while the Unit is on standby.

For private listening

Connect a pair of headphones to the PHONES jack. No sound comes out of the speakers.

Be sure to turn down the volume before connecting or putting on headphones.

Reinforcing the Bass Sound (AHB PRO)

You can reinforce the bass sound to maintain rich, full bass at low volume (you can use this effect only for playback):

To get the effect, press the AHB (Active Hyper Bass) PRO button.

The BASS indicator lights up on the display.

To cancel the effect, press the button again.

The BASS indicator goes out.

Controlling the Tone (Bass/Treble)

You can control the tone by changing the bass and treble.

Adjusting the bass level -----

You can adjust the bass level (low frequency range level) between -5 and +5. (0: Flat)

- 1 Press the BASS button on the Remote Control.
- 2 Press the UP or DOWN button on the Remote Control to adjust the bass level.

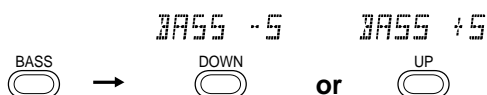

Adjusting the treble level -----

You can adjust the treble level (high frequency range level) between -5 and +5. (0: Flat)

- 1 Press the TREBLE button on the Remote Control.
- 2 Press the UP or DOWN button on the Remote Control to adjust the treble level.



Showing the Clock Time

In Standby mode, the digital clock appears on the display.

When the System is turned on, you can display the digital clock any time.

To display the digital clock, press the CLOCK button on the Unit or DISPLAY button on the Remote Control.



To return to the previous mode, press the same button again.

Note: To let the clock work, you need to set the clock beforehand. (See "Setting the Clock" on page 21.)

Using the Tuner

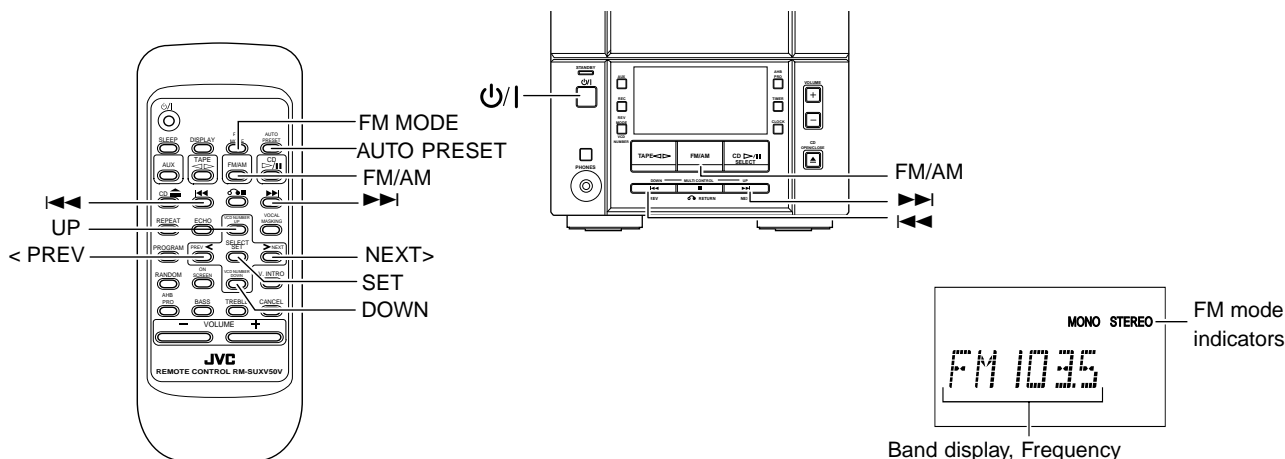

When the System is in use, the display shows other items as well. For simplicity, only the items described in this section are shown here.

You can listen to FM and AM stations. Stations can be tuned in manually, automatically, or from preset memory storage.

- Before listening to the radio:
 - Make sure that both the FM and AM antennas are correctly connected. (See page 3.)

Setting the AM tuner interval spacing

When shipped, the AM tuner interval is set to 9 kHz or 10 kHz spacing (Initial setting: U/UB/US/UT/UX...9 kHz). You can change it to 10 kHz or 9 kHz spacing.

To select 10kHz intervals, while holding down the ►►► button on the unit in Standby mode, press the P/I button on the unit to turn on the power. (At the same time, the 100kHz spacing is selected for FM broadcast)

To select 9kHz intervals again, while holding down the ◀◀◀ button on the unit in Standby mode, press the P/I button on the unit to turn on the power.



UB... Hong Kong	UX... Saudi Arabia
US... Singapore	UT... Taiwan ROC

Note: When you change the setting, the preset stations are erased. You will need to preset the stations again. (See page 9.)

One touch radio

Just press the FM/AM button to turn on the System and start playing the station you were last tuned to.

- You can switch from any other sound source to the radio by pressing the FM/AM button.

Tuning In a Station

- 1 Press the FM/AM button.
The band and frequency you were last tuned to appear on the display.
(If the last station was selected using the preset number, the preset number appears first.)
Each time you press the button, the band alternates between FM and AM.

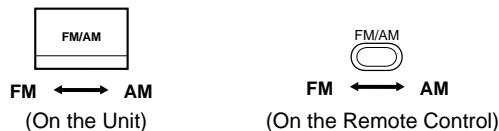

- 2 Select a station using one of the following methods.
 - **Manual Tuning**
Press the ◀◀◀ or ►►► button repeatedly to move from frequency to frequency until you find the station you want.

OR

- **Auto Tuning**
If you press and hold the ◀◀◀ or ►►► button for one second or more, the frequency changes down, or up, automatically until a station is found.

OR

- **Preset Tuning using the Remote Control (Possible only after presetting stations)**
Select the desired preset number using the UP, DOWN, > or < button on the Remote Control. After one second the display will show the preset number's band and frequency.
Example: To select preset number 12, press the UP button until "P12" appears.

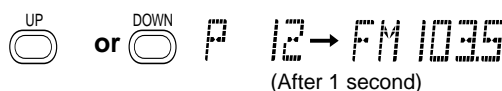

Presetting Stations

You can preset up to 30 FM stations and up to 15 AM stations using the Remote Control.

Note: Preset numbers may have been set to factory test frequencies prior to shipment. This is not a malfunction. You can preset the stations you want into memory by following one of the presetting methods below.

Presetting stations manually -----

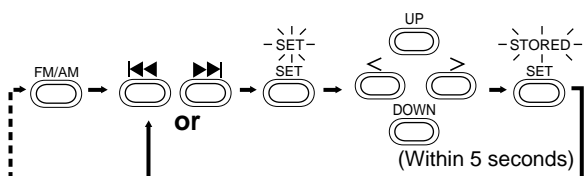

When changing the Band FM = 30, AM = 15

- 1 Select a band by pressing the FM/AM button.
- 2 Press the ◀◀ or ▶▶ button to tune in a station.
- 3 Press the SET button.
“SET” will flash for 5 seconds.
Within 5 seconds, proceed to the next step.
When the display returns to the one set in Step 2 after 5 seconds, press the SET button again.
- 4 Press the UP, DOWN, > or < button within 5 seconds to select the preset number.
UP or > button: Increases the preset number by 1.
DOWN or < button: Decreases the preset number by 1.
 - When the > or < button is held down, the preset number changes rapidly.
- 5 Press the SET button within 5 seconds.
“STORED” appears and after 2 seconds, the display returns to the broadcast frequency display.
- 6 Repeat above steps 1 to 5 for each station you want to store in memory with a preset number.

To change the preset stations, repeat the same steps as above.

Presetting stations automatically ---

In each band, you can automatically preset 30 FM and 15 AM stations. Preset numbers will be allocated as stations are found, starting from the lowest frequency to the highest frequency.

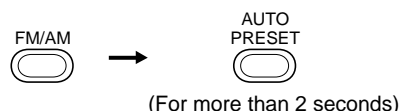

- 1 Select a band by pressing the FM/AM button.
- 2 Press the AUTO PRESET button on the Remote Control for more than 2 seconds.
- 3 Repeat steps 1 and 2 for the other band.

- If you want to change the preset stations, carry out the Manual Presetting for the desired preset numbers.

CAUTION:

Even if the system is unplugged or if a power failure occurs, the preset stations will be stored for about 24 hours. However, in case the preset stations are erased, you will need to preset the stations again.

Changing the FM Reception Mode

When you have tuned into an FM stereo broadcast, the STEREO indicator lights up and you can hear stereo effects. If an FM stereo broadcast is hard to receive or noisy, you can select Monaural mode. Reception improves, but you lose stereo effects.

Press the FM MODE button on the Remote Control so that the MONO indicator lights up on the display.



STEREO ↔ MONO

To restore the stereo effect, press the FM MODE button on the Remote Control so that the MONO indicator goes off.

Using the CD Player (Audio CDs)

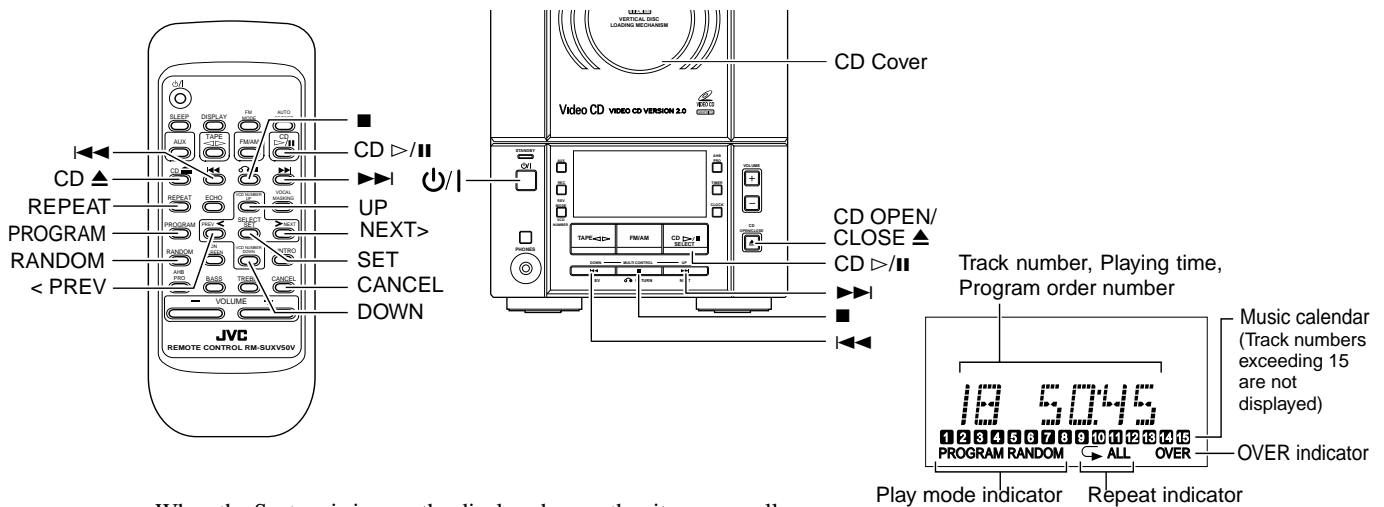

When the System is in use, the display shows other items as well.
For simplicity, only the items described in this section are shown here.

You can use Normal, Random, Program or Repeat Play. Repeat Play can repeat all the tracks or just one of the tracks on the CD. Here are the basic things you need to know to play a CD and locate the different tracks on it.

The quickest way to start a CD is with the one touch operation

- Press the CD > / || button on the Unit or the Remote Control.
- The power is automatically turned on. If a CD is already inserted, it will start playing from the first track.
- If no CD is inserted, "NO DISC" appears on the display and the CD Player remains in Stop mode.

Inserting a CD

- 1 Press the CD OPEN/CLOSE ▲ button on the Unit (or the CD ▲ button on the Remote Control.)
The CD cover opens.
- 2 Place a CD, with its label side out as shown below. Press down on the portions around the CD's center hole until you hear a click.

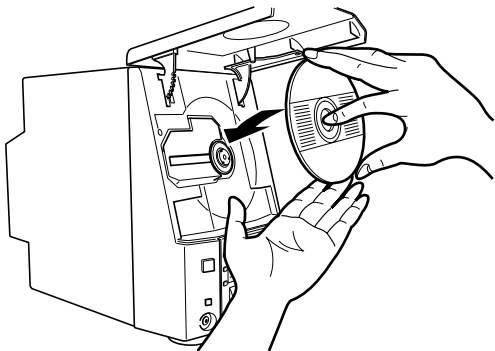

- 3 Press the CD OPEN/CLOSE ▲ button on the Unit (or the CD ▲ button on the Remote Control) again to close the CD cover.

- To close the CD cover and play the CD, you can just press the CD > / || button.
- You can place an 8 cm CD without an adaptor.
- When a CD with 16 tracks or more is loaded, the OVER indicator will light up on the display.
- If the CD cannot be read correctly (because it is scratched, for example), "00 0000" appears on the display.
- You can insert a CD while listening to another source.

CAUTIONS:

- DO NOT try to open or close the CD cover by hand as it will be damaged.
- When you place or take out a CD, do not let it fall. Be careful not to scratch your fingers with the CD cover.

Unloading a CD

Take out the CD as shown below.

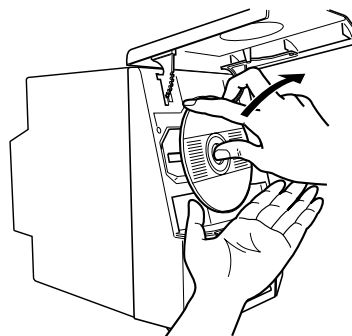

Basics of Using the CD Player — Normal Play

Playing a CD

- 1 Insert a CD.
- 2 Press the CD ▷/|| button.
The first track of the CD begins playing.

01 0005
Track number Playback time

- The track number that has already played disappears from the music calendar.
- The CD Player automatically stops when the last track of the CD has finished playing.

To stop playing the CD, press the ■ button.
The following information for the CD is displayed.

10 5045
Total track number Total playback time

To stop playing and remove the CD, press the CD OPEN/CLOSE ▲ button on the Unit or CD ▲ button on the Remote Control to open the CD cover. Then remove the CD.

To pause, press the CD ▷/|| button. The playback time flashes on the display.

To cancel pause, press the same button again. Play continues from the point where it was paused.

Selecting a track

During playback, press the ◀◀ or ▶▶ button (or the <, >, DOWN or UP button on the Remote Control) to select the track you want. The selected track starts playing.

- Press the ▶▶ button (or the > or UP button on the Remote Control) once to skip to the beginning of the next track.
- Press the ◀◀ button (or the < or DOWN button on the Remote Control) to skip to the beginning of the track being played. Press twice quickly to skip to the beginning of the previous track.
- When the > or < button on the Remote Control is held down, the tracks are successively skipped.

Selecting a passage within a track

Holding down the ◀◀ or ▶▶ button (or the DOWN or UP button on the Remote Control), during playback, will fast-forward/reverse the CD so you can quickly find a particular passage in the track you are listening to.

Programming the Playing Order of the Tracks

You can program the playing order of the tracks **using the Remote Control**.

- You can program up to 20 tracks in any desired order including the same tracks.
- You can only make a program when the CD Player is stopped.

- 1 Insert a CD.
- 2 Press the CD ▷/|| button.
- 3 Press the ■ button to stop the CD.

- 4 Press the PROGRAM button.
The System enters the programming mode and the PROGRAM indicator lights up.

PROGRAM
PROGRAM

- 5 Press the > or < button to select the track to program.
> button: Increases the track number by 1.
< button: Decreases the track number by 1.
 - When the > or < button is held down, the track number changes rapidly.

- 6 Press the SET button.

PROGRAM order number
02 P04
0357
Total playback time of the programmed tracks

- 7 Repeat steps 5 and 6 to select the other tracks for the program.

You can see the total playback time of programmed tracks on the display. You can also see the programmed tracks on the music calendar.

- 8 Press the CD ▷/|| button.

The System plays the tracks in the order you have programmed them.

- You can skip to a particular program track by pressing the ◀◀ or ▶▶ button (or the <, >, DOWN or UP button on the Remote Control) during Program Play.

- To stop playing, press the ■ button once.

To confirm the programmed tracks while the CD player is stopped, press the PROGRAM button; the tracks making up the program will successively be displayed in the programmed order.

To delete all the tracks in the program while the CD player is stopped, press the ■ button. Pressing the CD ▲ button on the Remote Control (or the CD OPEN/CLOSE ▲ button on the Unit) to open the CD cover will also clear the programmed tracks.

To exit from the program mode while the CD player is stopped, press the PROGRAM button on the Remote Control to light off the PROGRAM indicator. All the programmed tracks will be cleared.

Notes:

- If the total playback time of the programmed tracks exceeds 99 minutes 59 seconds, "-- : --" appears on the display.
- If you try to program the 21st track, "FULL" appears on the display for about 2 seconds.

Modifying the program

Modify the contents of the program while the CD Player is stopped. Each time you press the CANCEL button, the last track in the program is deleted. To add new tracks to the end of the program, repeat above steps 5 to 7.

Playing at Random

The tracks will play in no particular order when you use this mode.

Press the RANDOM button on the Remote Control.

The RANDOM indicator lights up on the display, and tracks will be played in random order.

To skip a track during playback, press the ►► button (or the > or UP button on the Remote Control) to jump to the next randomly selected track. Press the ◀◀ button (or the < or DOWN button on the Remote Control) to jump back to the start of a track being played.

To exit from Random Play mode, while the CD Player is stopped, press the RANDOM button on the Remote Control.

Repeating Tracks

You can set the program or individual track currently playing to repeat as many times as you like.

Press the REPEAT button on the Remote Control.

The Repeat indicator changes at each press of the button, as shown below.

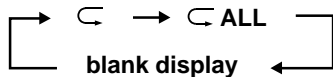

◀ : Repeats one track.

◀ ALL : In Normal Play mode, repeats all the tracks.
 In Program Play mode, repeats all the tracks in the program.
 In Random Play mode, repeats all the tracks in random order.

To exit from Repeat mode, press the REPEAT button until the Repeat indicator on the display goes out.

- In Random Play ◀ cannot be selected.
- Repeat mode remains in effect even when you change the play mode.

Locking the CD cover

You can lock the CD cover and prohibit the removal of the CD.

- This operation is possible only using the buttons on the unit.

To lock the CD cover, press the ◯/| button while holding the ■ button. (If the CD cover is opened, close it first.) “LOCKED” appears for a while, and the CD cover is locked.

To unlock the CD cover, press the ◯/| button while holding the ■ button. “UNLOCKED” appears for a while, and the CD cover is unlocked.

Note: If you try to unload the CD, “LOCKED” appears to inform you that the CD cover is locked.

Using the Video CD Player (Video CDs and CD-Gs)

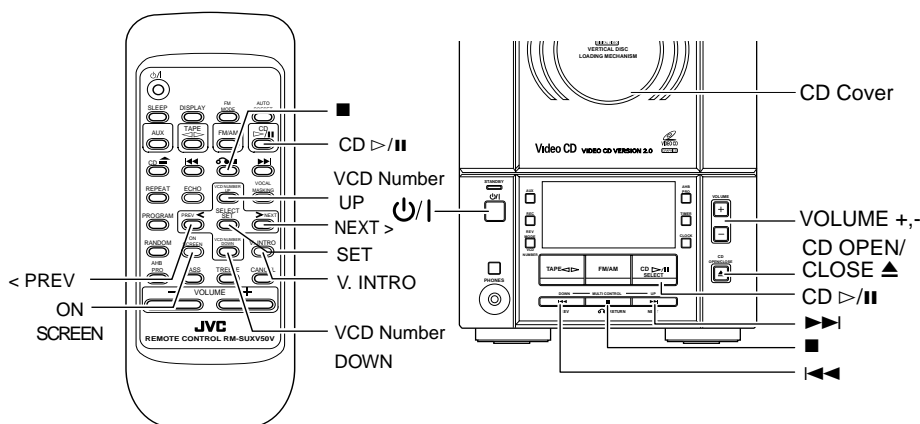

When the System is in use, the display shows other items as well.
For simplicity, only the items described in this section are shown here.

You can play video CDs (with or without the Playback Control (PBC) function) and CD Graphics (CD-Gs) to watch the picture on your TV while listening to the sound through your JVC Micro Component System.

- Before playing video CDs and CD-Gs
 - Make sure that the connection between the System and your TV is correct. If you wish, you can listen to the music on your TV by connecting the LINE OUT signals to your TV. (See page 4)

Setting the TV System

To view a picture of video CDs or CD-Gs, it is required that you set your CD player's TV output mode according to your TV's color system.

Relationship among the playable CDs, System's TV output mode and your TV's color system:

Playable CD	Player's TV output mode	Your TV's color system
NTSC/PAL	NTSC	NTSC
NTSC/PAL	PAL	PAL
NTSC/PAL	PAL AUTO	Multisystem

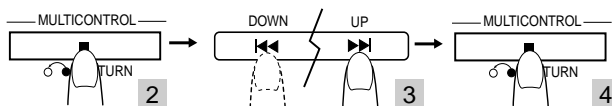

- 1 Turn off the power to put the System into Standby mode.

- 2 Press the ■ button on the Unit for more than 2 seconds.
The current TV output mode ("NTSC" for example) appears on the display for five seconds.

- 3 Within five seconds, press the ▶▶ or ◀◀ Button on the Unit to select the System's TV output mode.

Each time you press the button, the TV output mode changes as follows:

NTSC ⇄ PAL ⇄ PAL AUTO ⇄ (back to beginning)

NTSC: for NTSC exclusive TV

PAL: for PAL exclusive TV

PAL AUTO: for multisystem TV

- 4 Within five seconds, press the ■ button on the Unit to apply the changes.
- 5 Turn on the TV and select the video input on the TV.
- 6 Press the AUX or TAPE ◀▷ button to turn on the System.
"Video CD JVC" screen will appear on the TV without distortion.

Notes:

- If you play an NTSC CD in PAL AUTO mode on a PAL exclusive TV, the image may be distorted. If this happens change the CD Player's TV output mode to "PAL".
- When you play an NTSC CD in PAL AUTO mode on a multisystem TV, the image may blink for a moment. This symptom occurs when the System detects the formula of the CD and is not a malfunction.
- You can configure the current TV output mode anytime by pressing the ■ button on the Unit for more than 2 seconds.

Playing Video CDs with PBC Function

The System provides Playback Control (PBC) which utilizes a procedure (menu selection) programmed into a VCD.

What is the Playback Control (PBC) function?

PBC allows you to enjoy the following features:

- **Menu-Driven Play**
You can interact with the TV screen using a menu display to select and play an entry.
 - **High resolution still image playback**
You can display high-quality images four times clearer than video pictures.
- For operation, refer to the instructions supplied for the video CD.
- To use a Karaoke video CD, see page 24.
- You can play video CDs with PBC function using the menu screen (Menu-Driven Play) or without using the menu screen (Continuous Play).

Notes:

- **The playback operation procedure may differ depending on the video CD you use.**
- Sometimes due to improper manufacturing, video CDs will function differently.

Playing Video CDs with the PBC Function without Using the Menu Screen (Continuous Play)

You can play video CDs with PBC without using the menu screen, as if the CDs had no PBC function.

- 1 Load a video CD with PBC.
- 2 Press the CD ▷/|| button.

Program Play, Random Play, Repeating Tracks:

Select the mode by pressing the respective button on the Remote Control in the same way as for audio CDs. (See pages 11 and 12)

Playing Video CDs with the PBC Function Using the Menu Screen (Menu-Driven Play)

- Before playing, make sure that Repeat indicator "⏮" or "⏮ ALL" is not lit. If lit, press the REPEAT button on the Remote Control until "PBC" appears on the display.
- 1 Load a video CD with PBC.
Do not press the CD ▷/|| button yet.
 - 2 Press "REPEAT" button 3 times
(To select Playback mode). "PBC" appears on the display. Each time you press the "REPEAT" button, the mode (indicated on the TV screen) changes as follows:
PBC OFF/REPEAT OFF → REPEAT 1 → REPEAT ALL
↑ PBC ON ←
 - 3 Press the CD ▷/|| button.
"PBC" appears on the display and the first menu will appear on the TV screen.
 - If you leave your System on its own, the TV screen will change as follows:

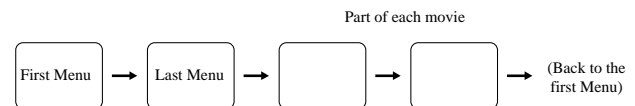

To return to the previous menu, press the ⏪ RETURN button on the Unit or the ⏪ ■ button on the Remote Control.

- 4 To move through the next menu, press the following button.
On the Unit:
Press the NEXT or PREV button.
On the Remote Control:
Press the NEXT or PREV button.

- 5 To select the item (track) in the menu and play it, press the following buttons.
On the Unit:
 1. Press the REV MODE / VCD NUMBER button. "SEL 1" will blink on the display.
 2. Press the ►► / ◀◀ buttons to select the item ("SEL XX") and press the SELECT button to play it back.

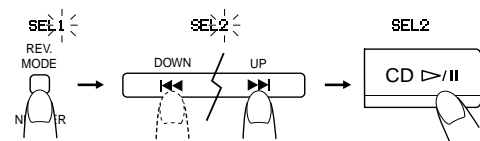

Basic Remote Control and Unit Button Functions for Menu-Driven Play:

Remote Control	Unit*	Function
PREV / NEXT	PREV / NEXT	Move through menu.
VCD NUMBER UP/DOWN	REV MODE / VCD NUMBER ↓ ◀◀ / ►►	Select a specific menu item.
SELECT	SELECT	Enters the selected video CD number or item. When a part of movie is displayed on the TV screen, starts playing that track from the beginning.
⏪ ■	⏪ RETURN	Returns to the previous menu during playback. Stops the video CD during playback when pressed for more than 2 seconds.

* The PBC function button names on the unit and the Remote control are printed in orange.

Example of playback using Playback Control (PBC)

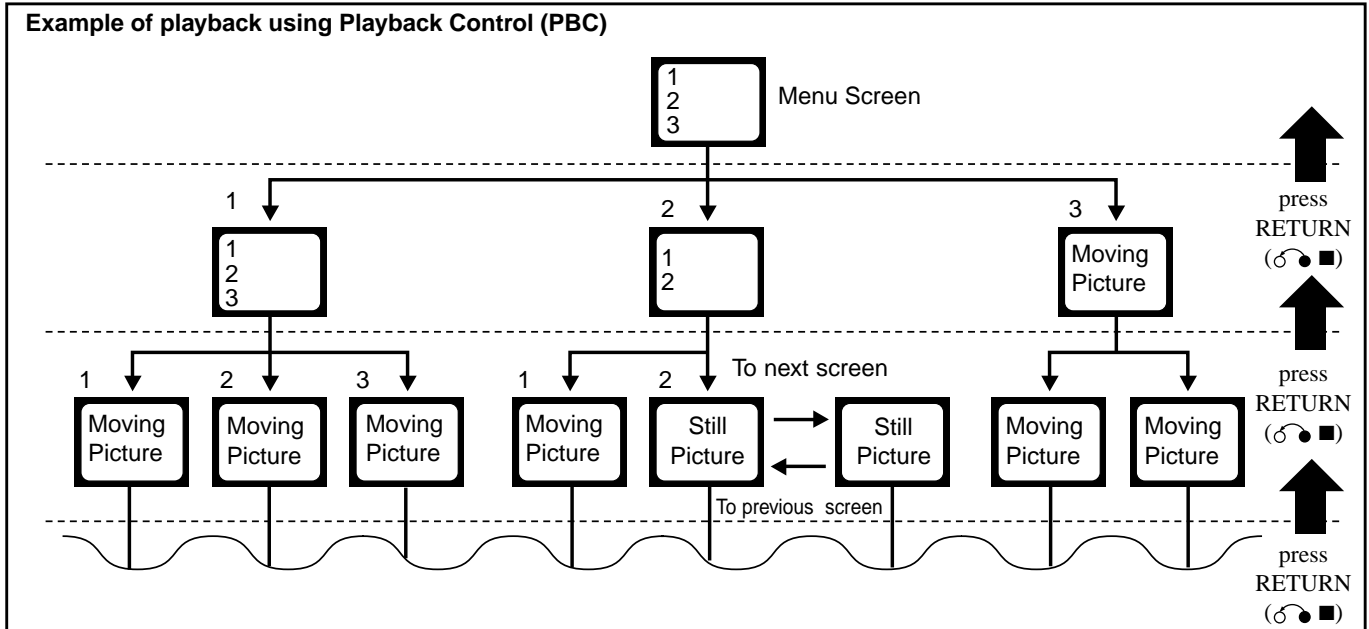

On the Remote Control:

1. Press the VCD NUMBER UP or DOWN button to select the item ("SEL XX") you want to play.
2. Press the SELECT button to play it back.

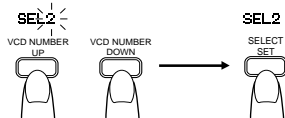

- The next track will be automatically played after the current track is finished.
- While a part of a movie is displayed on the TV in step 2, pressing the SELECT button on the Unit or the Remote Control causes the track being played to restart.

To pause, press the CD ▷/II button on the Remote Control.

To stop playback and return to the first menu, press the RETURN (⏪) button repeatedly.

To stop the video CD, press the RETURN (⏪) button for more than 2 seconds during playback. A blue screen appears on the TV.

To select other items during playback, repeat step 4.

Notes:

- Program Play, Random Play and Repeating Tracks cannot be performed during Menu-Driven Play.
- When the video CD is paused for about 10 minutes, the screen background automatically fades out to prevent screen burn-in.

A selection menu is displayed when you start playing a video CD with PBC. The selection menu shows a list of numbers for selection. Some video CDs may show moving pictures or a divided screen.

- When a list of numbers is displayed, selecting a number shows its contents.
- When a moving picture is displayed, pressing SELECT when the part of the movie you desire is shown plays the movie.
- When the selection menu is re-displayed after you have played your selection, selecting a number again can replay its contents. (Some video CDs may show the menu screen several times) When "NEXT" and "PREV" are shown, pressing NEXT or PREV can change the selection menu.
- After playback, press RETURN (⏪) to go back to the previous screen. After playback, pressing RETURN (⏪) for 2 seconds or more causes it to stop. Some video CDs may return you to the menu screen shown before playback.

Notes:

- When a menu screen of a karaoke disc is displayed for about a few minutes without any selection being made, it automatically starts playing from the first song.
- If a Video CD/Super Video CD is paused for about 10 minutes, the screen background automatically fades out to prevent screen burn in while the setting is suspended.
- When using the REPEAT function, the PBC function is not available.

Playing video CDs without PBC

Basic playback procedures for video CDs are the same as for audio CDs. (see pages 10-12)

- When you start playing a video CD without PBC, "VIDEO CD" appears on the display.
- To use a karaoke video CD without PBC, see page 24.

Notes:

- During playback of a video CD, the following operations may distort the image on the TV screen. Searching for the beginning of the track, Skipping tracks, Stopping/pausing the tracks, or frame-by-frame playback.
- If paused for more than 10 minutes, the screen background automatically fades out to prevent screen burn-in.

Playing CD-Gs

Basic playback procedures for CD-Gs are the same as for audio CDs. (See pages 10 and 11)

- When you start playing a CD-G, "GRAPHICS" appears on the display.
- To use a CD-G as a Karaoke source, see page 24.

Notes:

- During playback of a CD-G, the following operations may distort the image on the TV screen. Searching for the beginning of the track, Skipping tracks, Stopping/pausing the tracks.
- If paused for more than 10 minutes, the screen background automatically fades out to prevent screen burn-in.

Various Functions to Enhance Your Enjoyment

You can use the following features **using the Remote Control**.

Frame-by-Frame Playback

Frame-by-Frame playback is possible only when moving pictures (of the video CDs with or without PBC) are played.

During playback, press the CD ▷/II button to pause the video CD and then press the ►► button.

Each time you press the ►► button, the picture advances by one frame. During Frame-by-Frame playback, no sound will be heard.

- You cannot return to the previous frame. (The ◀◀ button is ineffective)

To resume Normal Play, press the CD ▷/II button.

Display of Operating Status

You can view the current operating status on the TV screen.

Press the ON SCREEN button.

Pressing the above button alternates between on-screen display ON and OFF. The following screens are shown for 3 seconds.

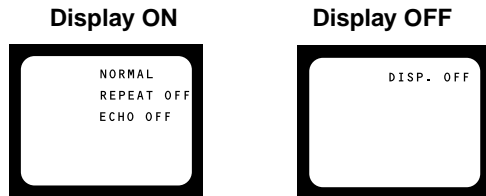

- Once you have turned on the on-screen display, the track number and playing time are always displayed on the TV screen. When you play a video CD with PBC, "PBC" will also be displayed on the TV screen.

Viewing the Video Intro of Video CDs

You can check the contents of a video CD, watching the first 5 seconds of each track on the disc.

- Play the video CD with or without PBC.
 - Load the video CD with or without PBC.
 - Press the CD ▷/II button.
- Press the V.INTRO button after a picture appears on the TV screen.

The Video Intro Play starts and the first 5-second portions of the first nine tracks are played in sequence.

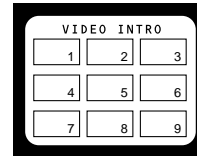

- If the video CD has more than nine tracks, the tracks whose track number is greater than nine will be displayed after the first nine tracks have been displayed.

To select a track during Video Intro Play, press the VCD NUMBER UP or DOWN buttons on the Remote Control to select the track and then press the SELECT button. Continuous play starts from the selected track. When you use the Unit, press the REV MODE/VCD NUMBER button and press the ◀◀ or ►► buttons to select the track, then press the CD ▷/II button.

To stop and cancel the Video Intro Play, press the RETURN (◁●■) button.

Using the Cassette Deck (Listening to a Tape)

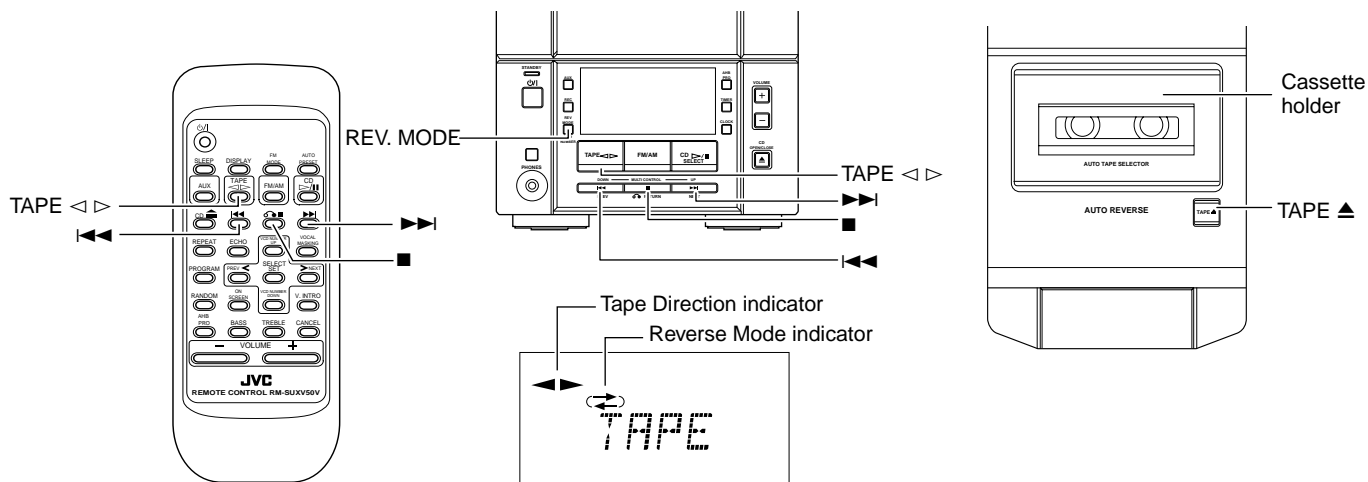

When the System is in use, the display shows other items as well.
For simplicity, only the items described in this section are shown here.

The Cassette Deck allows you to play and record audio tapes.

- With Automatic Tape Detection, you can listen to type I, II or IV tapes without having to change any settings.

The use of tapes longer than 120 minutes is not recommended, since characteristic deterioration may occur and these tapes easily jam in the pinch-rollers and the capstans.

One touch play -----

By pressing the TAPE $\triangleleft \triangleright$ button on the Unit or the Remote Control, the Unit will come on, "TAPE" appears on the display, and if a tape is in the deck, it will start to play. If no tape is loaded, the Unit will come on and wait for you to insert a tape, or select another function.

- 5 If you need to change the playback direction, press the TAPE $\triangleleft \triangleright$ button again.

The other Tape Direction indicator lights up and the tape playback direction changes.

To stop playing, press the ■ button.

To remove the tape, stop the tape, and press the TAPE \blacktriangle button on the Unit.

Fast-winding a tape -----

- Press the $\blacktriangleright \blacktriangleright$ or $\blacktriangleleft \blacktriangleleft$ button to fast-wind the tape.
 - The Cassette Deck automatically stops when the tape reaches its end.

Standard Play

When the power is already on, you can use this basic procedure:

- 1 Press the TAPE \blacktriangle button on the Unit.
- 2 When the cassette holder opens, put the cassette in, with the side you want to listen to facing up.
 - If the cassette holder does not open, turn off the Unit, then turn it back on and press the TAPE \blacktriangle button again.

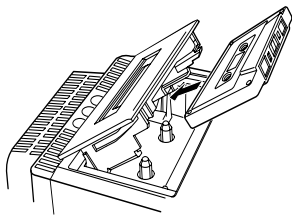

- 3 Close the holder gently until it clicks.
- 4 Press the TAPE $\triangleleft \triangleright$ button.
The tape is played in the direction shown by the Tape Direction indicator.

Reverse Mode

You can set the cassette deck to play one side of a tape, both sides once, or both sides continuously.

Press the REV. (reverse) MODE button on the Unit.

The indicator changes at each press of the button as shown.

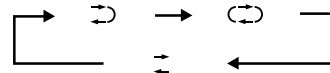

- \blacktriangleright : The Cassette Deck automatically stops after playing both sides of the tape. (Stops when playback in the \blacktriangleleft direction is finished.)
- \blacklozenge : The Cassette Deck continues to play both sides of the tape until the ■ button is pressed.
- \blacktriangleleft : The Cassette Deck automatically stops after playing one side of the tape.

Using the Cassette Deck (Recording)

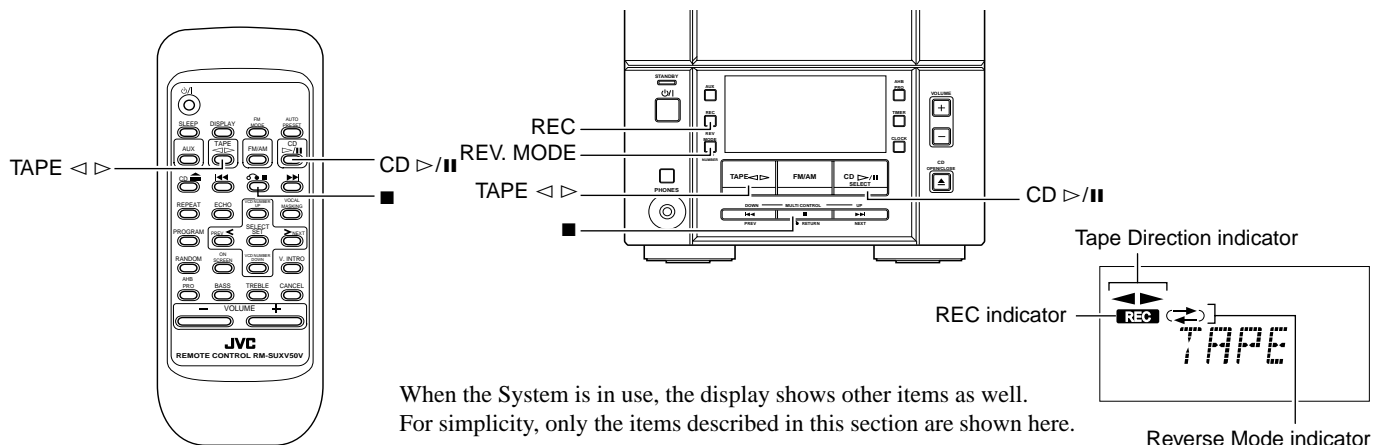

Recording onto a tape from any of the sound sources is simple. Just place a tape in the Cassette Deck, have the source ready, make one or two settings, and you're ready to record. For each source the procedure is a little different so we explain each separately. But first, here are a few tips for making better recordings.

Things to know before you start recording

- It may be unlawful to record or play back copyrighted material without the consent of the copyright owner.
- When you want to record onto both sides of a tape, you can set Reverse mode to do so. Recording automatically stops after recording in the ◀ direction. Therefore, make sure that the tape direction is ▶ when recording with Reverse mode on.
- The recording level, which is the volume at which the new tape is being made, is automatically set correctly, so it is not affected by the VOLUME control on the System. Nor is it affected by adjusting the sound effects. Thus, during recording you can adjust the sound you are actually listening to without affecting the recording level.
- Two small tabs on the back of the cassette tape, one for side A and one for side B, can be removed to prevent accidental erasure or recording.

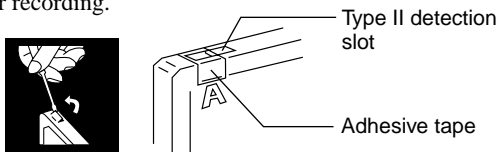

- To record on a cassette with the tabs removed, you must cover the holes with adhesive tape first. However, when a type II tape is used, only cover part of the hole as shown, since the other part of the hole (Type II detection slot) is used to detect the tape type.
- Type I and Type II tapes can be used for recording.

Note: At the start and end of cassette tapes, there is leader tape which cannot be recorded onto. Thus, when recording CDs or radio broadcasts, wind on the leader tape first to ensure that the recording will be made without any music part lost.

CAUTION:

If a recording you make has excessive noise or static, the Unit may have been too close to a TV which was on during the recording. Either turn off the TV or increase the distance between the TV and the System.

Standard Recording

You can record any sound source to tape as follows:

- 1 Insert a blank or erasable tape into the Cassette Deck.
 - 2 If you want to record on both sides of a tape, press the REV. MODE button on the Unit until the ⇄ indicator is lit.
 - When using Reverse mode, insert the tape so that it will be recorded in the forward ▶ direction.
 - 3 Check the recording direction for the tape.

Make sure that the Tape Direction indicator is the same as that for the tape in the Cassette Deck. If the direction is different, press the TAPE <|> button to correct the tape direction and then press the ■ button to stop the tape.
 - 4 Prepare the source by, for example, tuning in a radio station or turning on connected auxiliary equipment.
- Note:** For CD recording, refer to "CD Direct Recording" on page 19.
- 5 Press the REC button on the Unit.

The REC indicator lights up and the System begins recording.

Notes for using Reverse mode for recording

When recording in Reverse mode, the System automatically stops when it reaches the end of the reverse ◀ direction. To record on both sides of a tape, make sure that the recording direction for the tape inserted is forwards ▶, and that the Tape Direction indicator is also forwards ▶, before you start recording.

To stop at any time during the recording process

Press the ■ button.

CD Direct Recording

Everything on the CD goes onto the tape in the order it is on the CD, or according to the order you have set in a program.

- 1 Insert a blank or erasable tape into the Cassette Deck.
- 2 Insert a CD.
- 3 Press the CD ▷/|| button.
- 4 Press the ■ button.
 - If you want to record specific tracks only, program the tracks beforehand. You can check their total playback time on the display during programing. (See page 11.)
- 5 If you want to record on both sides of a tape, press the REV. MODE button on the Unit until the ⇌ indicator is lit.
 - Make sure that the recording direction for the tape and the Tape Direction indicator are correct. (See “Notes for using Reverse mode for recording” on page 18.)
- 6 Select whether to have pauses left between recorded selections.
 - If nothing is done, a non-recorded pause of about four seconds will be automatically left between selections.
 - If you do not want pauses left between selections, do the following before proceeding to the next step.
Press the CD ▷/|| button twice.
 The CD player enters Pause mode.
- 7 Press the REC button on the Unit.
 The REC indicator lights up and the System begins recording.
 - When recording a CD onto tape with Reverse mode on:
 If a song is recorded for more than 12 seconds (which corresponds to the length of leader tape) but not finished before the first side of tape comes to an end, this song will automatically be recorded on the second side from its beginning to avoid being split on both sides.
 If a song is recorded for less than 12 seconds before the first side of tape comes to an end, the song preceding this song will also be recorded on the second side from its beginning as it may not be completely recorded on the first side because of leader tape.
 - After the CD player has played the entire CD, or all the programmed tracks, the tape automatically stops.

To stop at any time during the recording process, press the ■ button. The tape stops after 4 seconds.

Note: When making SLEEP timer settings while doing CD Direct recording, set enough time to allow for the CD to finish playing, otherwise the power will go off before recording is completed.

One track recording

- 1 Insert a blank or erasable tape into the Cassette Deck.
- 2 Play the track on the CD you wish to record.
- 3 Press the REC button on the Unit.
 The CD player returns to the beginning of that track and the track is recorded on the tape. After recording, the CD player and Cassette Deck automatically stop.

Using External Equipment

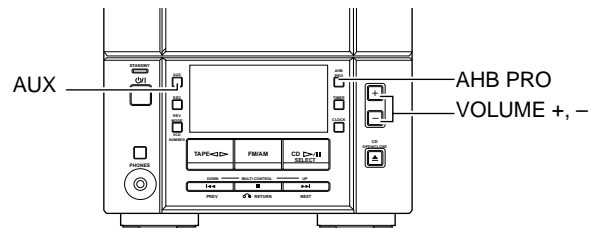
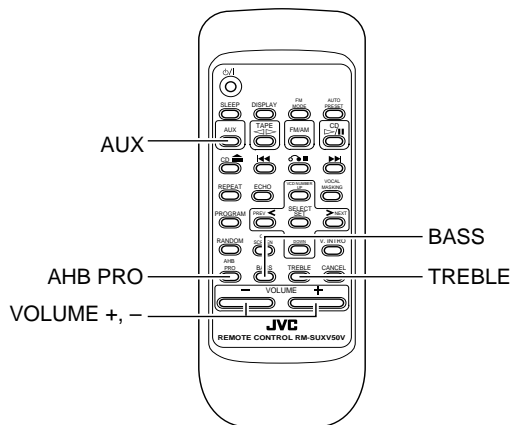

Listening to External Equipment

You can connect various external equipment.

For Hong Kong, the external equipment is used as playback and recording device. For the other areas, it is used only as a playback device.

- First make sure that the external equipment is properly connected to the System. (See page 4.)

- 1 Set the VOLUME control to the minimum position.
 - 2 Press the AUX button.
“AUX” appears on the display.
- AUX*
- 3 Start playing the external equipment.
 - 4 Adjust the VOLUME control to the desired listening level.
 - 5 Apply sound effects, if you wish.
 - Press the AHB PRO button to reinforce the bass sound.
 - Press the BASS/TREBLE button on the Remote Control to control the tone. (See “Controlling the Tone (Bass/Treble)” on page 7.)

To exit from AUX mode, select another source.

Notes:

- For operation of the external equipment, refer to its Instructions.
- For recording from the external equipment, refer to “Standard Recording” on page 18.

Recording the System's Source to External Equipment (For Hong Kong only)

You can record the System's sources to external equipment which is connected to the LINE OUT or OPTICAL DIGITAL OUT terminal of the System, such as cassette deck or MD recorder, etc.

- First make sure that the external equipment is properly connected to the System. (See page 4.)

Play the System's CD Player or Cassette Deck, or tune into a station.

- The recording level is not affected by the VOLUME level. It is not affected by any sound effect, either.

Note: For operation of the external equipment, refer to its Instructions.

Using the Timers

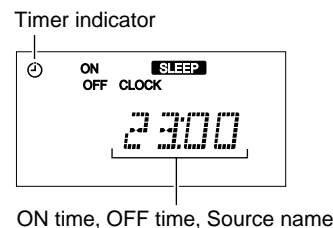
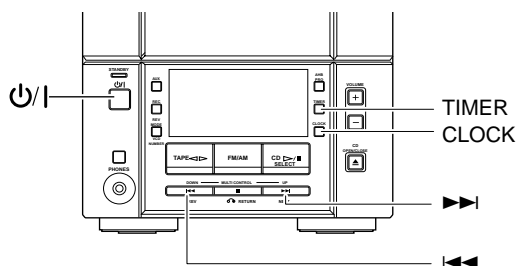
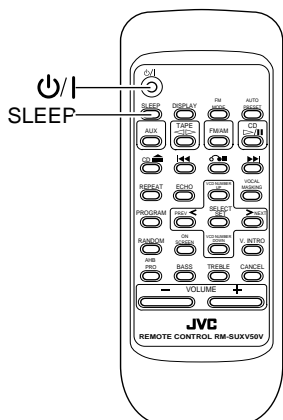

ON time, OFF time, Source name

When the System is in use, the display shows other items as well. For simplicity, only the items described in this section are shown here.

The timers let you control listening and recording functions automatically.

Setting the Clock

- When you plug the AC power cord into the wall outlet, the CLOCK indicator flashes on the display.

You can set the clock whether the System is on or off.

Notes:

- The clock must be correctly set for the timers to work.
- The procedure must be completed within 2 minutes. Otherwise, the setting is cleared and must be repeated from the beginning.

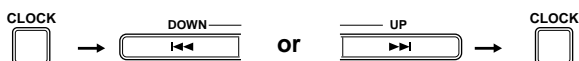

(For 2 seconds)

- Press the CLOCK button on the Unit for more than 2 seconds.
The hour digits rapidly flash on the display.
- Press the ►► or ◄◄ button to set the hour.
Pressing the ►► button moves the hour forwards and pressing the ◄◄ button moves it backwards. Hold down the button to move the hour rapidly.
- Press the CLOCK button.
The minute digits rapidly flash on the display.
- Press the ►► or ◄◄ button to set the minute.
Pressing the ►► button moves the minute forwards and pressing the ◄◄ button moves it backwards. Hold down the button to move the minute rapidly.
- Press the CLOCK button again.
The selected time is set and the seconds start counting from 0.
The CLOCK indicator remains lit on the display.

CAUTION:

If the System is unplugged, or a power failure occurs, the timer setting will be lost. You will need to reset the clock first, then the timer.

Note: The clock may gain or lose 1 to 2 minutes per month.

Setting the Daily Timer

Once you have set the Daily Timer, the timer will be activated at the same time every day. It can be canceled and re-activated whenever you wish.

The Timer indicator on the display shows when the Daily Timer you have set will be activated.

Notes:

- Finish each step within 30 seconds. Otherwise, the setting is cleared and the procedure must be repeated from the beginning.
- The clock must be correctly set for the timers to work.
If the clock has not been set, the CLOCK indicator will flash on the display when you press the TIMER button for more than 2 seconds, and then the display alternates between "ADJUST" and "CLOCK" for about 5 seconds.

- Press the TIMER button on the Unit for more than 2 seconds.

The ON indicator lights up, and then the current ON time flashes on the display. (Example: 12:00)

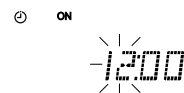

- Set the ON time. (Example: 12:15)

Press the ►► or ◄◄ button on the Unit to set the hour you want the Unit to come on.

Pressing the ►► button moves the hour forwards and pressing the ◄◄ button moves it backwards. Hold down the button to move the hour rapidly. Press the TIMER button to adjust the minute.

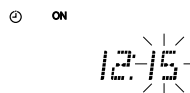

- Set the OFF time. (Example: 13:15)

- Press the TIMER button on the Unit.
The hour digits of the current OFF time flashes, and then the OFF indicator lights up on the display.

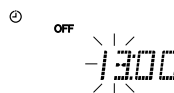

- Press the ►► or ◄◄ button on the Unit to set the time you want the Unit to be turned off.
Pressing the ►► button moves the hour forwards and pressing the ◄◄ button moves it backwards. Hold down the button to move the hour rapidly. Press the TIMER button again to adjust the minute.

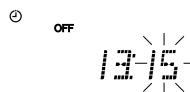

4 Select the source.

1. Press the TIMER button on the Unit.
“TUNER” flashes on the display.
2. Press the ►► or ◄◄ button to select the source you want to listen to.
The display changes as shown below.

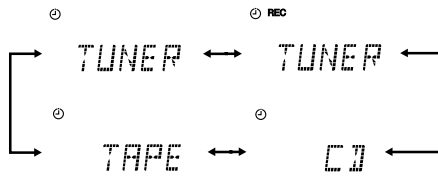

5 Set the volume level.

1. Press the TIMER button on the Unit.
The current volume setting flashes on the display.
2. Press the ►► or ◄◄ button to select the volume level.
-- : The current volume level will be used.
0 to 40 : When the timer is turned on, the volume will be automatically set to the selected level.



6 Press the TIMER button on the Unit.

The timer setting is completed and the display returns to the indications before you set the timer. The Timer indicator remains lit.

7 Before turning off the System, prepare the source selected in step 4.

TUNER: Tune in to the desired station.
REC TUNER: See “Setting the Recording Timer.”
CD: Insert a CD.
TAPE: Insert a tape.

8 Press the ⏻ button to turn off the System.

To cancel the timer, press the TIMER button for more than 2 seconds. The Timer indicator goes out on the display.

To re-activate the canceled timer, press the TIMER button for more than 2 seconds to light the Timer indicator. Then, press the TIMER button until the display returns to the previous indications. The Timer indicator should remain lit.

To confirm the timer settings, cancel the timer once by pressing the TIMER button, and press the button again for more than 2 seconds. Then, press the TIMER button repeatedly, to see the current timer settings (ON time, OFF time, source, and volume). Press the TIMER button to set the timer again.

To change the timer setting, repeat the setting procedure from the beginning.

- When the timer turns on, the Timer indicator starts flashing.

Note: If the Unit is turned on when the timer-on time comes, Daily Timer does not work.

CAUTION:

If the System is unplugged, or a power failure occurs, the timer will be canceled. You will need to reset the clock first, then the timer.

Setting the Recording Timer

With the Recording Timer, you can make a tape of radio broadcast automatically.

How Recording Timer actually works

The Unit automatically turns on, tunes into the last received station, and starts recording when the on-time comes. Then, when the off-time comes, the Unit automatically turns off (stands by). The timer setting remains in memory until you change it.

Notes:

- Finish each step within 30 seconds. Otherwise, the setting is cleared and the procedure must be repeated from the beginning.
- The clock must be correctly set for the timers to work. If the clock has not been set, the CLOCK indicator will flash on the display when you press the TIMER button for more than 2 seconds, and then the display alternates between “ADJUST” and “CLOCK” for about 5 seconds.

1 Press the ⏻ button to turn on the System.

2 Tune in to the desired station.

See page 8.

3 Press the TIMER button on the Unit for more than 2 seconds.

The ON indicator lights up, and then the current ON time flashes on the display. (Example: 12:00)

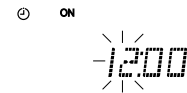

4 Set the ON time. (Example: 12:15)

Press the ►► or ◄◄ button on the Unit to set the hour you want the Unit to come on.

Pressing the ►► button moves the hour forwards and pressing the ◄◄ button moves it backwards. Hold down the button to move the hour rapidly. Press the TIMER button to adjust the minute.

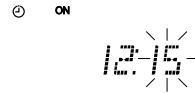

5 Set the OFF time. (Example: 13:15)

1. Press the TIMER button on the Unit.
The hour digits of the current OFF time flashes, and then the OFF indicator lights up on the display.

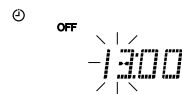

2. Press the ►► or ◄◄ button on the Unit to set the time you want the Unit to be turned off.

Pressing the ►► button moves the hour forwards and pressing the ◄◄ button moves it backwards. Hold down the button to move the hour rapidly. Press the TIMER button again to adjust the minute.

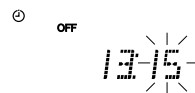

6 Press the TIMER button on the Unit.

- 7 Press the ►► or ◀◀ button until "TUNER" appears and the REC indicator lights up on the display.

The display changes as shown below.

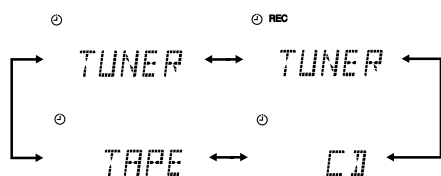

- 8 Set the volume level.

1. Press the TIMER button on the Unit.
The current volume setting flashes on the display.
2. Press the ►► or ◀◀ button to select the volume level.
-- : The current volume level will be used.
0 to 40 : When the timer is turned on, the volume will be automatically set to the selected level.

To turn off the volume while the Recording Timer is working, set the volume level to "0."

- 9 Press the TIMER button on the Unit.

The timer setting is completed and the display returns to the indications before you set the timer. The Timer indicator remains lit.

Note: If you change the station before turning off the System, the last received station will be recorded.

- 10 Insert a blank or erasable tape into the Cassette Deck.

- Make sure that the tape has the enough length for recording.

- 11 Press the ⏻ button to turn off the System.

To cancel the timer, press the TIMER button for more than 2 seconds. The REC and Timer indicators go out on the display.

To re-activate the canceled timer, press the TIMER button for more than 2 seconds to light the REC and Timer indicators.

To confirm the timer settings, cancel the timer once by pressing the TIMER button, and press the button again for more than 2 seconds. Then, press the TIMER button repeatedly, to see the current timer settings (ON time, OFF time, source, and volume). Press the TIMER button to set the timer again.

To change the timer setting, repeat the setting procedure from the beginning.

- When the timer turns on, the Timer indicator starts flashing.

Note: If the Unit is turned on when the timer-on time comes, Recording Timer does not work.

CAUTION:

If the System is unplugged, or a power failure occurs, the timer will be canceled. You will need to reset the clock first, then the timer.

Setting the Sleep Timer

When a source is playing, use the Sleep Timer to turn the System off after a certain number of minutes. By setting the Sleep Timer, you can fall asleep to music and know that your System will turn off by itself rather than play all night.

- You can only set the Sleep Timer when the System is on.

Note: The clock must be correctly set for the timers to work. If the clock has not been set, the CLOCK indicator will flash on the display when you press the TIMER button for more than 2 seconds, and then the display alternates between "ADJUST" and "CLOCK" for about 5 seconds.

- 1 Play a CD or a cassette tape, or tune in to the desired station.
- 2 Press the SLEEP button on the Remote Control.
The SLEEP indicator lights up.
- 3 Set the length of time you want the source to play before shutting off.
 - Each time you press the SLEEP button, it changes the number of minutes shown on the display in this sequence:

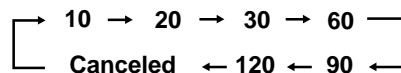

After setting the number of minutes for the Sleep Timer, the display will stop flashing and return to the previous state. The System is now set to turn off after the number of minutes you set.

To confirm the Sleep Time

When the SLEEP button is pressed, the remaining sleep time is displayed.

To cancel the Sleep Timer setting

Press the SLEEP button until the SLEEP indicator goes out on the display.

Turning off the System also cancels the Sleep Timer.

Using the Microphone

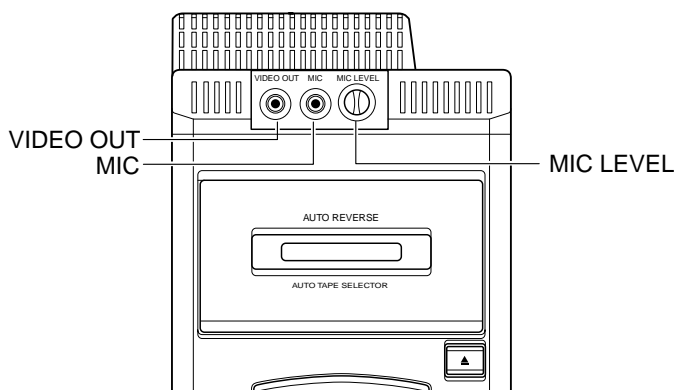
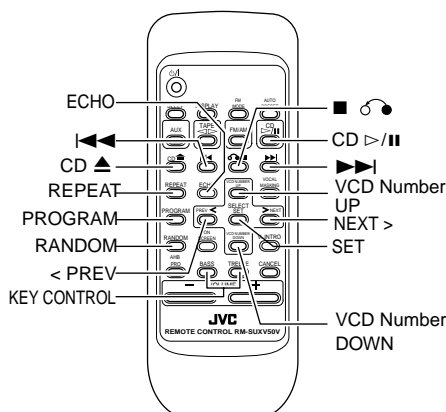

The system includes one microphone. By attaching the microphone, you can use the System for Karaoke or microphone mixing. You can also add an echo to the microphone's sound.

Note:

Karaoke and microphone mixing are only available when CD source is selected.

- The MIC LEVEL control adjusts the microphone volume when CD source is selected
- When you will not be using the microphone, keep the MIC LEVEL control set to MIN and disconnect the microphone.

CAUTION: Always set the MIC LEVEL control to MIN when connecting or disconnecting the microphone.

Singing Along - Karaoke

You can enjoy singing along using audio CDs, video CDs and CD-Gs. (Karaoke does not function for other sources such as tapes). While singing along, you can apply echo and adjust the music key.

Singing Along with Audio CDs — Vocal Masking

When playing an audio CD, you can reduce the lead vocal and replace it with your voice by singing into the microphone.

The following CDs are not suitable for Vocal Masking.

- Monoaural CDs
- Multiplex Karaoke CDs
- CD recorded duets, strong echo, a chorus, or only a few instruments

- 1 Set the MIC LEVEL control to MIN by turning it counterclockwise.
- 2 Connect the microphone by plugging it into the MIC jack.
- 3 Press the VOCAL MASKING button on the Remote Control until "V.MASKING" appears on the display.

Pressing the button alternates between Vocal Masking "ON" and "OFF" (NORMAL) as shown below:

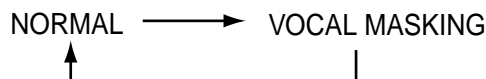

- 4 Play a CD.
- 5 Adjust the main volume and the MIC LEVEL control, as you sing into the microphone.
 - If you want to record on a tape, carry out CD Direct Recording or One Track Recording. (See page 18)

To cancel the Karaoke mode, press the VOCAL MASKING button on the Remote Control until "NORMAL" appears on the display.

Notes:

- After you have finished singing along, always cancel the Karaoke mode. Karaoke mode will also be cancelled if you change functions or turn off the power.
- If "howling" occurs, keep the microphone away from the speakers.
- When digital recording is made to the external equipment through the OPTICAL DIGITAL OUT terminal using an audio CD, the microphone sound is not recorded.
- During recording, you cannot change the Vocal Masking.

Applying an echo to your voice

You can apply echo to your voice through the microphone except when you select the Tuner as the source.

Press the ECHO button on the Remote Control until "ECHO ON" appears on the display.

Pressing the button alternates between echo ON and OFF. "ECHO ON" and "ECHO OFF" will appear on the display for 3 seconds.

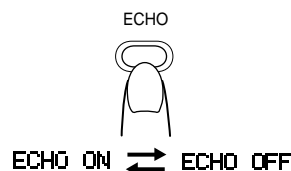

To cancel the echo, press the ECHO button again until “ECHO OFF” appears on the display. Selecting the Tuner or turning off the power will also cancel the echo.

Note:

During recording, you cannot switch the echo.

CAUTION: Always set the MIC LEVEL control to MIN when connecting or disconnecting the microphone.

Microphone Mixing

Using a microphone, you can mix the microphone sound with a CD sound.

Note:

Microphone mixing is only available for CD source.

- 1 Set MIC LEVEL control to MIN by turning it fully counterclockwise.
- 2 Connect a microphone (not supplied) by plugging it into the MIC jack.
- 3 Start the source: CD Only.

Note:
Microphone mixing is not available for other sources such as Tape, Tuner or Aux.
- 4 Adjust the main volume and the MIC LEVEL control as you sing into the microphone.
 - To apply echo, press the ECHO button on the Remote Control until “ECHO ON” appears on the display. To cancel the echo, press the same button again. “ECHO OFF” will appear on the display. Selecting the Tuner or turning off the power will also cancel the echo.

Note:

If “howling” occurs, keep the microphone away from the speakers.

To Record Microphone Mixing on a Tape

- 1 Follow the above steps 1-4.
- 2 To record, follow the steps in “Standard Recording”. (See page 18)

Note:

When digital recording is made to external equipment through the OPTICAL DIGITAL OUT terminal using an audio CD, the microphone sound is not recorded.

Care and Maintenance

Handle your CDs carefully, and they will last a long time.

Compact Discs



- Only CDs bearing these marks can be used with this System. However, continued use of irregular shape CDs (heart-shape, octagonal, etc.) can damage the System.

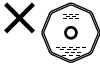
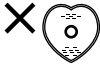

- Remove the CD from its case by holding it at the edges while pressing the case's center hole lightly.
- Do not touch the shiny surface of the CD, or bend the CD.



- Put the CD back in its case after use to prevent warping.
- Be careful not to scratch the surface of the CD when placing it back in the case.
- Avoid exposure to direct sunlight, temperature extremes, and moisture.



- A dirty CD may not play correctly. If a CD does become dirty, wipe it with a soft cloth in a straight line from center to edge.

CAUTION: Do not use any solvent (for example, conventional record cleaner, spray thinner, benzene, etc.) to clean a CD.

General Notes

In general, you will have the best performance by keeping your CDs and the mechanism clean.

- Store CDs in their cases, and keep them in cabinets or on shelves.
- Keep the system's CD cover closed when not in use.

Cleaning the Lens

If the lens in the CD pickup is dirty, sound degradation may take place.

Open the CD cover and clean the lens as shown.

- Use a blower (available from a camera store) to blow dust off the lens.

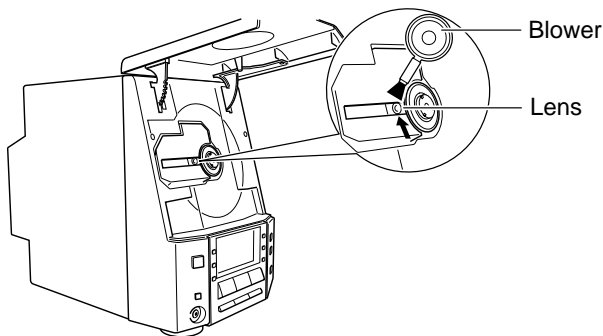

- If there are fingerprints, etc. on the lens, gently wipe clean with a cotton swab.

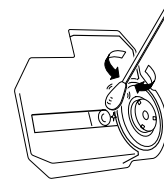

Moisture Condensation

Moisture may condense on the lens inside the System in the following cases:

- After turning on heating in the room
- In a damp room
- If the System is brought directly from a cold to a warm place



Should this occur, the System may malfunction. In this case, leave the System turned on for a few hours until the moisture evaporates, unplug the AC power cord, and then plug it in again.

Cassette Tapes

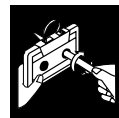

- If the tape is loose, it may get stretched, cut, or caught in the cassette. Take up the slack by inserting a pencil in one of the reels and rotating.



- Do not touch the tape surface.



- Do not store the tape:
 - In dusty places
 - In direct sunlight or heat
 - In moist areas
 - On a TV or speaker
 - Near a magnet

Cassette Deck

- If the heads, capstans, or pinch-rollers of the Cassette Deck become dirty, the following may occur:
 - Loss of sound quality
 - Discontinuous sound
 - Fading
 - Incomplete erasure
 - Difficulty in recording
- Clean the heads, capstans, and pinch-rollers using a cotton swab moistened with alcohol.

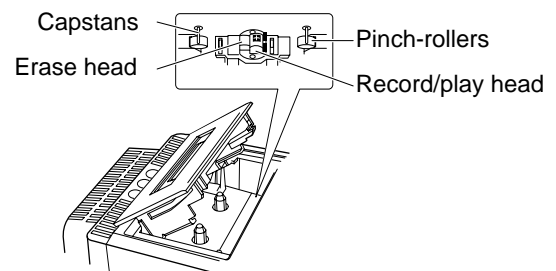

- If the heads become magnetized, the Unit will produce noise or lose high frequency notes.
- To demagnetize the heads, turn off the Unit, and use a head demagnetizer (available at electronics and record shops).

Troubleshooting

- If you are having a problem with your System, check this list for a possible solution before calling for service.
- If you cannot solve the problem from the hints given here, or the System has been physically damaged, call a qualified person, such as your dealer, for service.

Symptom	Possible Cause	Action
You cannot hear any sound	<ul style="list-style-type: none"> • Connections are incorrect, or loose. • Headphones are connected. 	<ul style="list-style-type: none"> • Check all connections and make corrections. (See pages 2 – 5.) • Disconnect the headphones.
Radio reception is poor	<ul style="list-style-type: none"> • Antennas are disconnected. • The AM Loop Antenna is too close to the System. • The FM Wire Antenna is not properly extended and positioned. 	<ul style="list-style-type: none"> • Reconnect the antenna securely. • Change the position and direction of the AM Loop Antenna. • Extend FM Wire Antenna to the best reception position.
The CD does not play.	The CD is upside down.	Put the CD in with the label side facing you.
The CD skips.	The CD is dirty or scratched.	Clean or replace the CD.
The CD cover does not open or close.	The AC power cord is not plugged in.	Plug the AC power cord.
The cassette holder cannot be opened.	During tape playing, the power cord has been unplugged.	Plug in the power cord, press the ⏻/ button, and then press the TAPE ▲ button.
You are unable to record.	Cassette record protect tabs are removed.	Cover the holes on the back edge of the cassette with adhesive tape.
All functions do not operate.	The built-in microprocessor has malfunctioned due to external electrical interference.	Unplug the System then plug it back in.
You are unable to operate the Remote Control.	<ul style="list-style-type: none"> • The path between the Remote Control and the sensor on the Unit is blocked. • The batteries have lost their charge. 	<ul style="list-style-type: none"> • Remove the obstruction. • Replace the batteries.
The image on the TV screen is distorted	VIDEO OUT selection does not match the TV set's colour system	Make sure the VIDEO OUT mode matches your TV's colour system. (See pages 4 and 13)
The disc sound loses stereo effect or lead vocals are not heard	The Vocal Masking function is in use	Press the Vocal Masking button on the Unit until "NORMAL" appears on the display
The picture of the video CD or CD-G is distorted	When you pause or skip the track, the pictures will be distorted. This is not a malfunction.	

Specifications

UX-V50V (CA-UXV50V and SP-UXV50V)
UX-V50GN (CA-UXV50GN and SP-UXV50GN)

Amplifier

Output Power	36 W (18 W + 18 W) at 4 Ω (Max.) 30 W (15 W + 15 W) at 4 Ω (10% THD)
Input Sensitivity/Impedance (1 kHz)	
LINE IN (AUX)	400 mV/48 kΩ
Output Sensitivity/Impedance (1 kHz)	
LINE OUT (For Hong Kong only)	260 mV/5.8 kΩ
Optical out (For Hong Kong only)	-21 dBm - -15 dBm
Speaker terminals	4 Ω - 16 Ω
Phones	16 Ω - 1 kΩ
	0 mW - 15 mW per channel output into 32 Ω

Cassette Deck

Frequency Response	
Type I (Normal)	50 Hz - 14 kHz
Type II (CrO ₂)	50 Hz - 15 kHz
Wow and Flutter	0.15% (WRMS)

CD Player

Signal-To-Noise Ratio	90 dB
Wow And Flutter	Immeasurable

Tuner

FM Tuner	
Tuning Range	87.5 MHz - 108.0 MHz
AM Tuner	
Tuning Range	531 kHz - 1,710 kHz (except for Saudi Arabia) 531 kHz - 1,602 kHz (for Saudi Arabia only) (at 9 kHz channel space)
	530 kHz - 1,710 kHz (except for Saudi Arabia) 530 kHz - 1,600 kHz (for Saudi Arabia only) (at 10 kHz channel space)

Speaker Specifications

(each unit)	
Speakers	Woofer 9 cm x 1. Tweeter 4 cm x 1
Impedance	4 Ω
Dimensions	140 mm x 230 mm x 226 mm (W/H/D)
Mass	Approx. 1.9 kg

General

Dimensions	438 mm x 234 mm x 279 mm (W/H/D)
Mass	Approx. 7.4 kg

Power Specifications

Power Requirements	AC 110 V/AC 127 V/AC 230 V \sim , adjustable with the voltage selector, 50 Hz/60 Hz
Power Consumption	45 W (power on mode) 3.7 W (in Standby mode)
Maximum Power Consumption	90 W (power on mode) (for Taiwan ROC only)

Accessories

See page 2.

Design and specifications are subject to change without notice.

Mains (AC) Line Instruction (not applicable for Europe, U.S.A., Canada, Australia, and U.K.)

主 (AC) 電源線路說明 (不適用於歐洲、美國、加拿大、澳洲及英國型號)

تعليمات خط التيار الكهربائي الرئيسي (المتردد) (لا تنطبق على اوروبا والولايات المتحدة الأمريكية وكندا واستراليا و المملكة المتحدة)

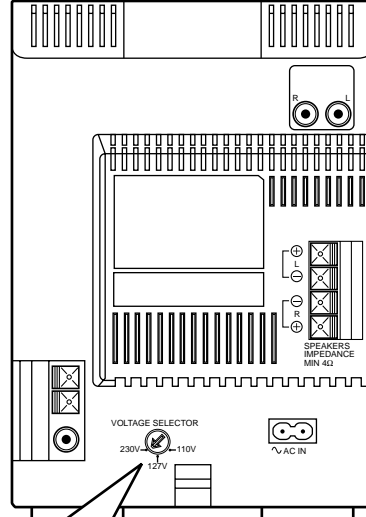
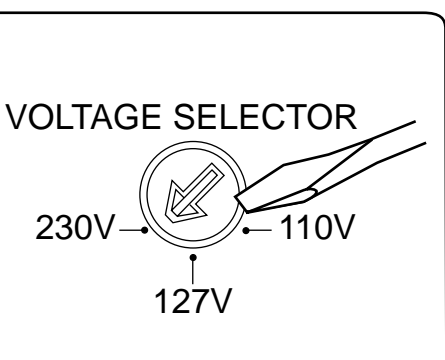

IMPORTANT for mains (AC) line
BEFORE PLUGGING IN, do check that your mains (AC) line voltage corresponds with the position of the voltage selector switch provided on the outside of this equipment and, if different, reset the voltage selector switch, to prevent from damage or risk of fire/electric shock.

有關主(AC)電源線路的重要事項
接插電源以前，務請檢查當地的主(AC)電源線路電壓是否和位於本機外面的電壓選擇開關設定的位置一致。如果不一致，即重新設定電壓選擇開關使符合當地電壓，以免損壞機器或引起火災/觸電的危險。

هام من اجل خط التيار الكهربائي الرئيسي (المتردد)
قبل ادخال قاييس الطاقة الكهربائية، تأكد من تطابق منتهي متخبط فولطية التيار الكهربائي الرئيسي (المتردد) الموجود على خلفية الجهاز مع فولطية التيار الكهربائي في بلدك. في حالة عدم التطابق، اعد ضبط مفتاح منتهي الفولطية على فولطية التيار الكهربائي المتردد في بلدك. عدم عمل ذلك، يمكن يؤدي الى حصول ضرر او حريق او صدمة كهربائية.